

ORDER INFORMATION AND DIMENSION:

Circuits	Part No.	Dimension		
		A	B	C
2	2640M0200	2.5	6.4	8.1
3	2640M0300	5.0	8.9	10.6
4	2640M0400	7.5	11.4	13.1
5	2640M0500	10.0	13.9	15.6
6	2640M0600	12.5	16.4	18.1
7	2640M0700	15.0	18.9	20.6
8	2640M0800	17.5	21.4	23.1
9	2640M0900	20.0	23.9	25.6
10	2640M1000	22.5	26.4	28.1
11	2640M1100	25.0	28.9	30.6
12	2640M1200	27.5	31.4	33.1
13	2640M1300	30.0	33.9	35.6
14	2640M1400	32.5	36.4	38.1
15	2640M1500	35.0	38.9	40.6

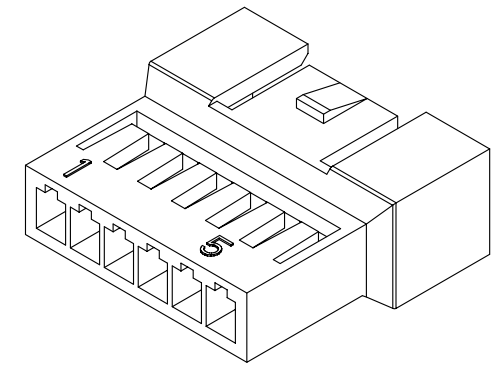
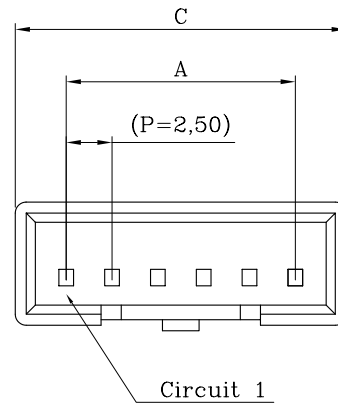

ISOMETRIC VIEW

DESCRIPTION OF ORDER NO.:

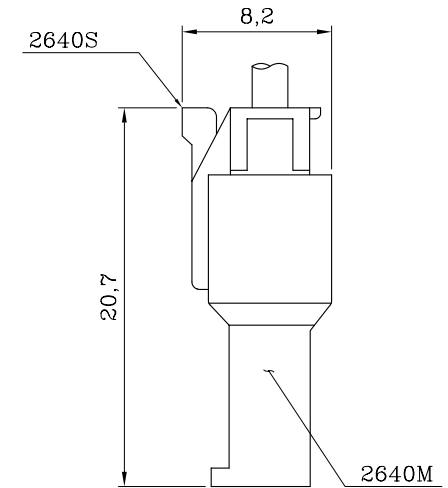
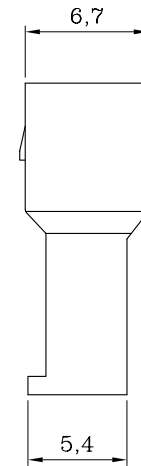
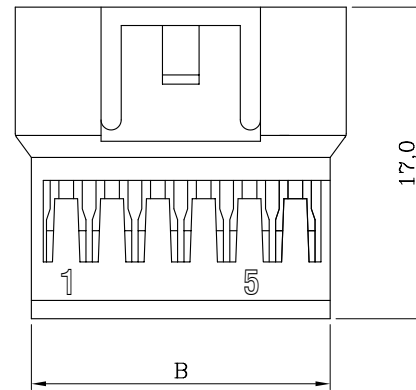
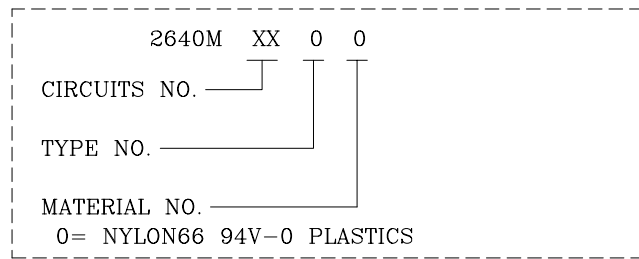

ASSEMBLY LAYOUT

NOTES:

- MATERIAL:  
BASE: NYLON66 94V-0, LIGHT IVORY COLOR (NATURAL)
- USE WITH 2643TM11X SERIES CRIMP TERMINAL.
- MATES WITH 2640S TYPE-A SERIES PLUG HOUSING.
- DESCRIPTION OF COLOR CODE:  
LEGEND: 2640MXX00-X (-X: COLOR CODE)  
B=BLACK, C=COCONUT BROWN, D=ORANGE, E=BLUE, H=GRAY,  
K=PURPLE, L=LEMON YELLOW, M=GREEN, P=PINK, R=RED,  
V=LAVENDER, W=BROWN, Y=YELLOW
- INFORMATION IN THIS DRAWING IS NOT CONSIDERED AS FINAL.



Sales Drawing



聯盈電子股份有限公司  
LANDWIN ELECTRONIC CORP.

MATERIAL: SEE NOTES		FINISH(COLOR): SEE NOTES		GENERAL TOLERANCE:		PROJECTION	SCALE	UNIT	SHEET NO.	REV
						⊕	FREE	MM	1 / 1	W1
						DRAWN	R.G.	DRAW NO.		
						CHECKED	J.L.Lin	(AQ) 2640MXX00		
						APPD	H.Y.Lin	TITLE:		
W1	NEW RELEASE	31-DEC-14'	ANGULAR ±3°	DATE	31-DEC-14'	2.50 PITCH SINGLE-ROW RECEPTACLE HOUSING				
REV.	REVISION RECORD	DATE								