

ORDER INFORMATION AND DIMENSION:

Circuits	Part No. (Matte tin-plated)	Dimension	
		A	B
2	3001P02 49V	NA	6.7
4	3001P04 49V	3.00	9.7
6	3001P06 49V	6.00	12.7
8	3001P08 49V	9.00	15.7
10	3001P10 49V	12.00	18.7
12	3001P12 49V	15.00	21.7
14	3001P14 49V	18.00	24.7
16	3001P16 49V	21.00	27.7
18	3001P18 49V	24.00	30.7
20	3001P20 49V	27.00	33.7
22	3001P22 49V	30.00	36.7
24	3001P24 49V	33.00	39.7

DESCRIPTION OF ORDER NO.:

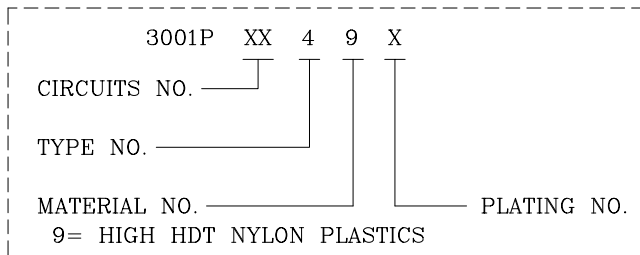

NOTES:

- MATERIAL:**
 BASE: HIGH HDT NYLON 94V-0, BLACK COLOR
 CONTACT PIN: BRASS
 SOLDER PEG: BRASS, MATTE TIN-PLATED
- MATES WITH 3000F DUAL-ROW SERIES PLUG HOUSING.
- DESCRIPTION OF COLOR CODE:**
 LEGEND: 3001PXX49X-X (-X: COLOR CODE)
 R=RED, E=BLUE, H=GRAY, M=GREEN, S=IVORY (NATURAL)
 I=BRICK RED,
- REPLACEMENT OF HALOGEN-FREE PRODUCT:**
 LEGEND: 3001PXX49X-XNH (NH: HALOGEN-FREE)
 LEGEND: 3001PXX49X-BNH (B=BLACK COLOR)
- INFORMATION IN THIS DRAWING IS NOT CONSIDERED AS FINAL.

DESCRIPTION OF PLATING CODE:	
V= MATTE TIN-PLATED	A= SELECT GOLD FLASH-PLATED

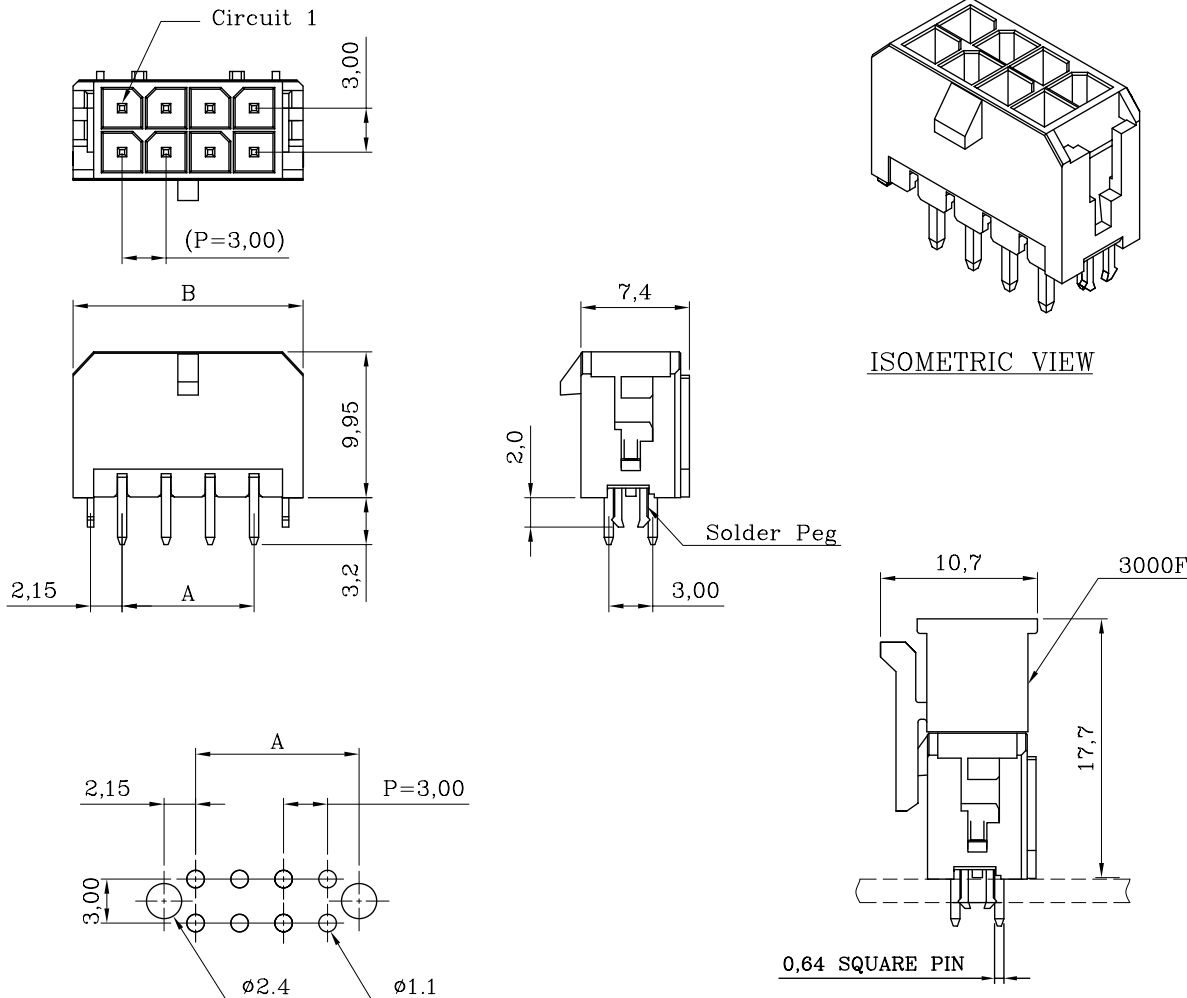

P.C. BOARD LAYOUT
(COMPONENT SIDE)

MATERIAL: SEE NOTES		ROHS RoHS Compliant		REACH REACH Compliant	
FINISH(COLOR): SEE NOTES					
W1	NEW RELEASE	31-DEC-14'	ANGULAR ±3°	DATE 31-DEC-14'	
REV.	REVISION RECORD	DATE			

ASSEMBLY LAYOUT

GWT 850 °C Rated		Sales Drawing			
LANDWIN 聯盈電子股份有限公司 LANDWIN ELECTRONIC CORP.					
GENERAL TOLERANCE:	PROJECTION ⊕	SCALE FREE	UNIT MM	SHEET NO. 1 / 1	REV W1
	DRAWN R.G.	DRAW NO.			
	CHECKED J.L.Lin	(CQ) 3001PXX49X			
	APPD H.Y.Lin	TITLE:			
		3.00 PITCH DUAL-ROW S/T HEADER (TYPE-4)			