

ORDER INFORMATION AND DIMENSION:

Circuits	Part No. (Matte tin-plated)	Dimension	
		A	B
2	3001P02 69V	NA	6.7
4	3001P04 69V	3.00	9.7
6	3001P06 69V	6.00	12.7
8	3001P08 69V	9.00	15.7
10	3001P10 69V	12.00	18.7
12	3001P12 69V	15.00	21.7
14	3001P14 69V	18.00	24.7
16	3001P16 69V	21.00	27.7
18	3001P18 69V	24.00	30.7
20	3001P20 69V	27.00	33.7
22	3001P22 69V	30.00	36.7
24	3001P24 69V	33.00	39.7

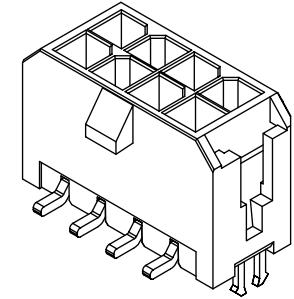

ISOMETRIC VIEW

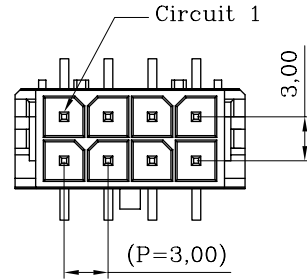
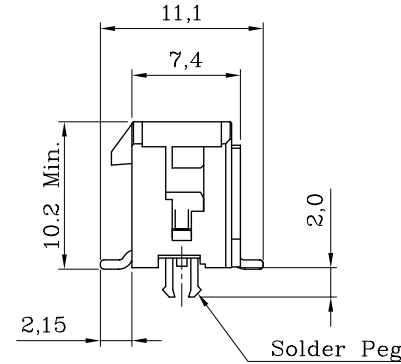
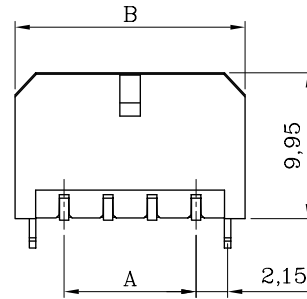

DESCRIPTION OF ORDER NO.:

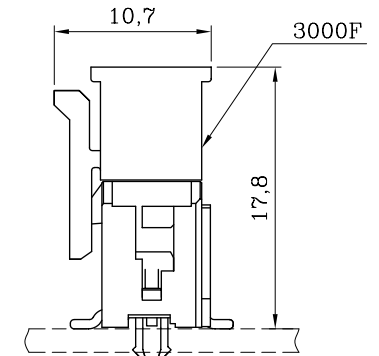
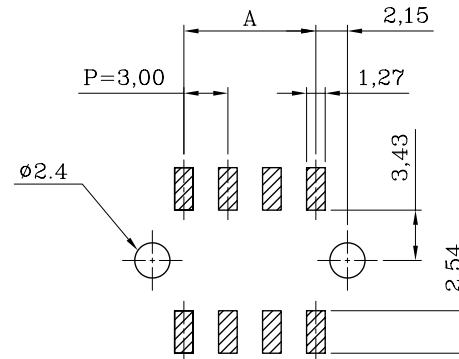
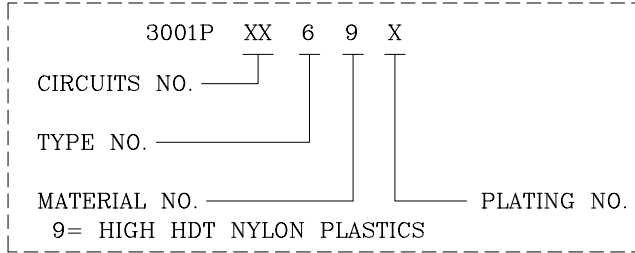

NOTES:

- MATERIAL:
BASE: HIGH HDT NYLON 94V-0, BLACK COLOR
CONTACT PIN: BRASS
SOLDER PEG: BRASS, MATTE TIN-PLATED
- MATES WITH 3000F DUAL-ROW SERIES PLUG HOUSING.
- DESCRIPTION OF COLOR CODE:
LEGEND: 3001PXX69X-X (-X: COLOR CODE)
R=RED, E=BLUE, H=GRAY, M=GREEN, S=IVORY (NATURAL)
I=BRICK RED,
- REPLACEMENT OF HALOGEN-FREE PRODUCT:
LEGEND: 3001PXX69X-XNH (NH: HALOGEN-FREE)
LEGEND: 3001PXX69X-BNH (B=BLACK COLOR)
- INFORMATION IN THIS DRAWING IS NOT CONSIDERED AS FINAL.

DESCRIPTION OF PLATING CODE:

V= MATTE TIN-PLATED A= SELECT GOLD FLASH-PLATED

P.C. BOARD LAYOUT
(COMPONENT SIDE)



GWT 850 °C Rated Sales Drawing

MATERIAL: SEE NOTES	
FINISH(COLOR): SEE NOTES	
W1	NEW RELEASE
REV.	REVISION RECORD

聯盈電子股份有限公司 LANDWIN ELECTRONIC CORP.		GENERAL TOLERANCE:	PROJECTION	SCALE	UNIT	SHEET NO.	REV
			⊕	FREE	MM	1 / 1	W1
		DRAWN	R.G.	DRAW NO.			
		CHECKED	J.L.Lin	(CQ) 3001PXX69X			
		APPD	H.Y.Lin	TITLE:			
W1		NEW RELEASE	31-DEC-14'	ANGULAR ±3°	DATE	31-DEC-14'	3.00 PITCH DUAL-ROW S/T HEADER (TYPE-6)