

ORDER INFORMATION AND DIMENSION:

Circuits	Part No. (Without Flange)	Dimension	
		A	B
2	3680F02 12	3.68	8.64
3	3680F03 12	7.36	12.45
4	3680F04 12	11.04	16.13

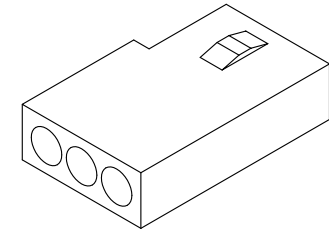
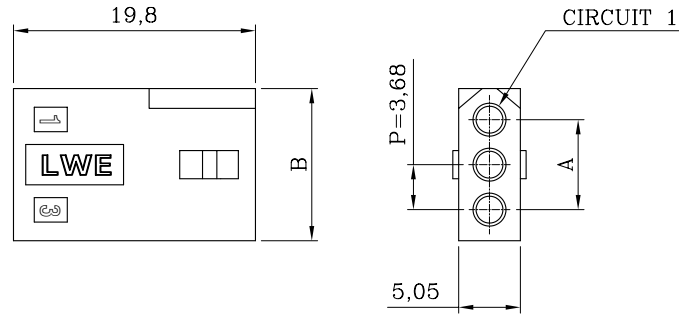

ISOMETRIC VIEW

DESCRIPTION OF ORDER NO.:

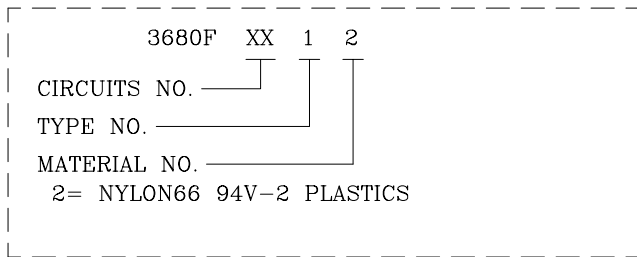

ASSEMBLY VIEW  
(Wire-to-wire Application)

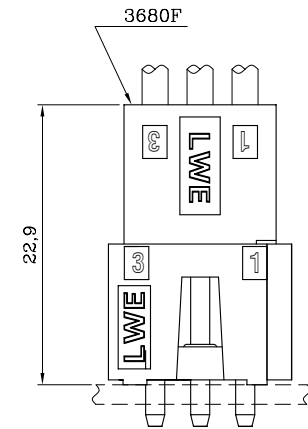

ASSEMBLY LAYOUT  
(Wire-to-wire Application)

NOTES:

- MATERIAL:  
BASE: NYLON66 94V-2, WHITE COLOR (NATURAL)
- USE WITH 3683TF SERIES CRIMP TERMINAL.
- MATES WITH 3681P SINGLE-ROW SERIES HEADER.  
MATES WITH 3680MXX12 SERIES RECEPTACLE HOUSING.
- DESCRIPTION OF COLOR NO.:  
LEGEND: 3680FXX12-X (-X: COLOR NO.)  
B=BLACK, C=COCONUT BROWN, E=BLUE, H=GRAY,  
I=BRICK RED, M=GREEN, R=RED, W=BROWN
- INFORMATION IN THIS DRAWING IS NOT CONSIDERED AS FINAL.



Sales Drawing

MATERIAL: SEE NOTES		FINISH(COLOR): SEE NOTES	
W1	NEW RELEASE	31-DEC-14'	ANGULAR ±3°
REV.	REVISION RECORD	DATE	

<b>LANDWIN</b> 聯盈電子股份有限公司		LANDWIN ELECTRONIC CORP.	
GENERAL TOLERANCE:	PROJECTION FREE	SCALE FREE	UNIT MM
	DRAWN R.G.	CHECKED J.L.Lin	SHEET NO. 1 / 1
	APPD H.Y.Lin	TITLE: 3.68 PITCH SINGLE-ROW PLUG HOUSING	REV W1
	DATE 31-DEC-14'	DRAW NO. (AQ) 3680FXX12	