

12 11 10 9 8 7 6 5 4 3 2 1

A

B

C

D

E

F

A

B

C

D

E

F

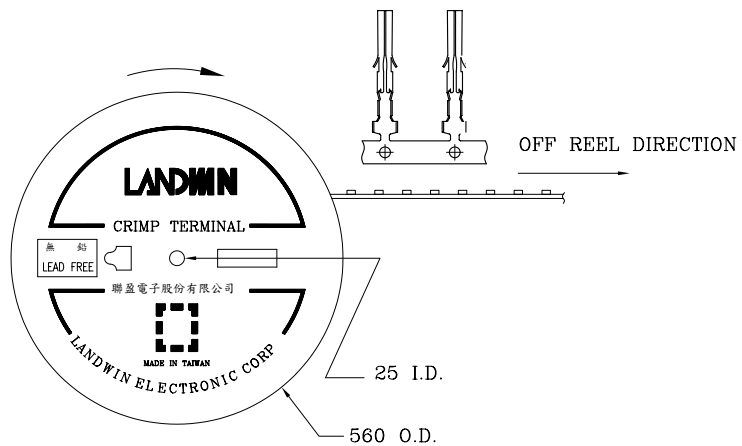

ROLL FORM PACKAGE

DESCRIPTION OF ORDER NO.:

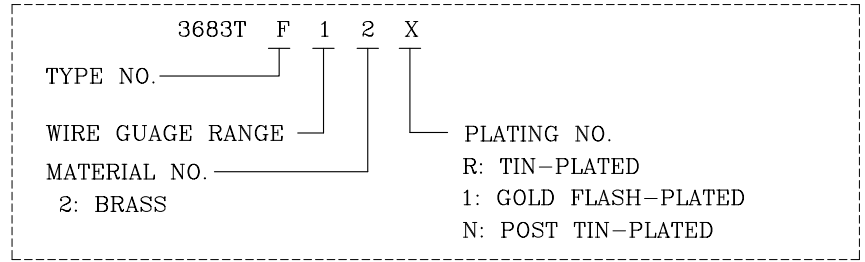

ORDER INFORMATION AND DIMENSION:

ORDER NO.	TERMINAL TYPE	WIRE GAUGE RANGE (AWG)	INSULATION DIAMETER	Q'TY/REEL
3683TF12X	CHAIN	#18 - #24	ø2.7 MAX.	6,000 PCS

NOTES:

- MATERIAL: BRASS
- USE WITH PLUG HOUSING:
<1> 3680F SERIES
- INFORMATION IN THIS DRAWING IS NOT CONSIDERED AS FINAL.

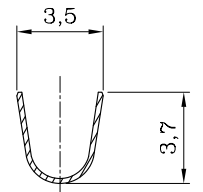
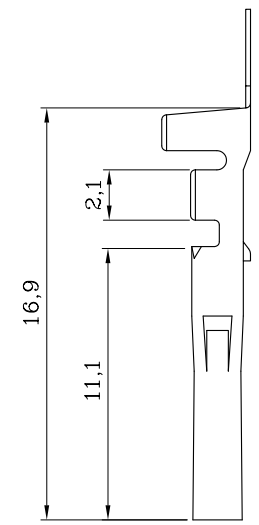
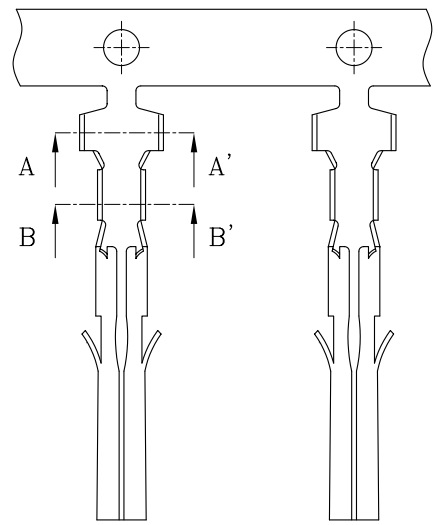

SEC. A-A'

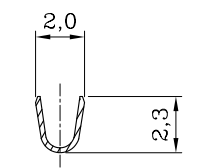

SEC. B-B'

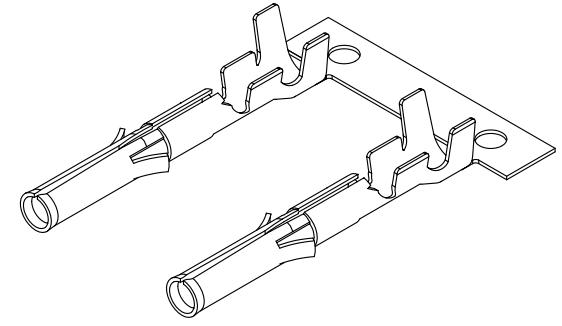
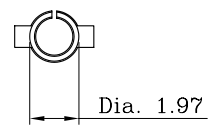

ISOMETRIC VIEW

		Sales Drawing			
		聯盈電子股份有限公司 LANDWIN ELECTRONIC CORP.			
GENERAL TOLERANCE:	PROJECTION: SCALE: FREE	UNIT: MM	SHEET NO. 1 / 1	REV. W1	
	DRAWN: R.G.	DRAW NO. (BQ) 3683TF12X			
	CHECKED: J.L.Lin	TITLE: CRIMP TERMINAL (3680F SERIES)			
	APPD: H.Y.Lin	DATE: 31-DEC-14'			
W1	NEW RELEASE	31-DEC-14'	ANGULAR ±3°		
REV.	REVISION RECORD	DATE			