

12 11 10 9 8 7 6 5 4 3 2 1

A

B

C

D

E

F

A

B

C

D

E

F

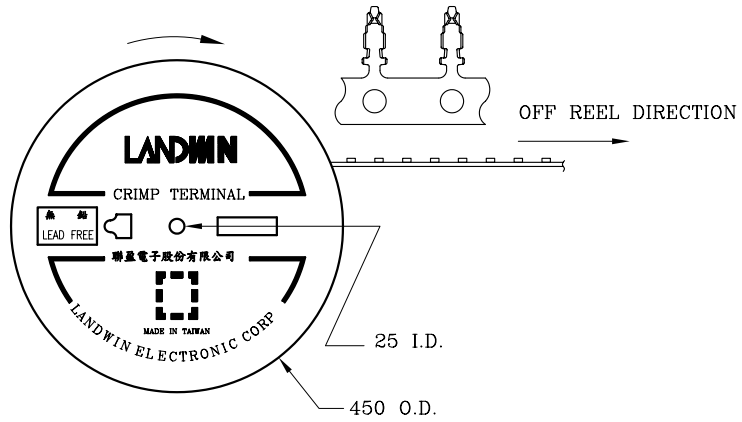

ROLL FORM PACKAGE

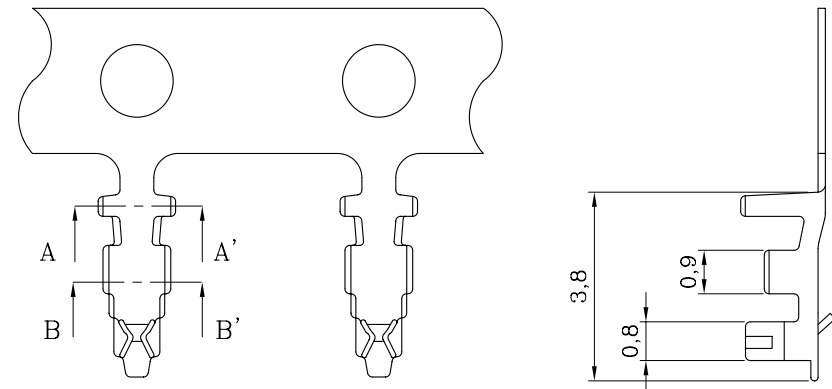

DESCRIPTION OF ORDER NO.:

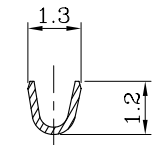
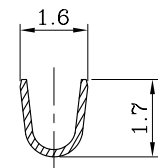
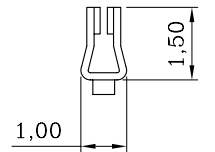
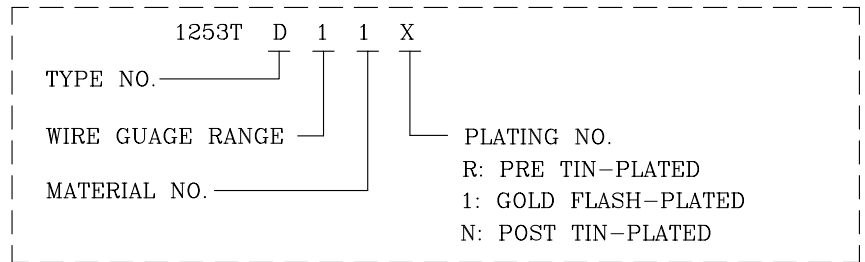

SEC. A-A'

SEC. B-B'

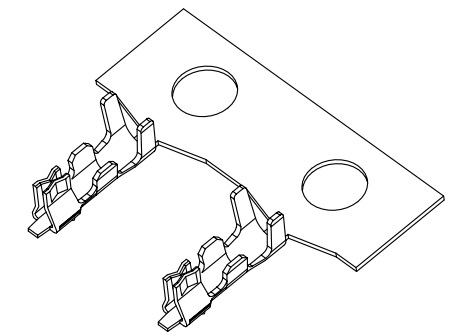

ISOMETRIC VIEW

ORDER INFORMATION AND DIMENSION:

ORDER NO.	TERMINAL TYPE	WIRE GAUGE RANGE (AWG)	INSULATION DIAMETER	Q'TY/REEL
1253TD11X	CHAIN	#26 ~ #30	ø1.0 MAX.	10,000 PCS

NOTES:

1. MATERIAL: PHOSPHOR BRONZE
2. USE WITH 1250SXXD0 SERIES TYPE-D PLUG HOUSING
3. INFORMATION IN THIS DRAWING IS NOT CONSIDERED AS FINAL.



Sales Drawing

**LANDWIN** 聯盈電子股份有限公司  
LANDWIN ELECTRONIC CORP.

MATERIAL: SEE NOTES		FINISH(COLOR): SEE NOTES	
W1	NEW RELEASE	31-DEC-14'	ANGULAR ±3°
REV.	REVISION RECORD	DATE	

GENERAL TOLERANCE:	PROJECTION	SCALE	UNIT	SHEET NO.	REV
	⊕	FREE	MM	1 / 1	W1
	DRAWN	R.G.	DRAW NO.		
	CHECKED	J.L.Lin	(BQ) 1253TD11X		
	APPD	H.Y.Lin	TITLE:		
			CRIMP TERMINAL (1250S TYPE-D SERIES)		